

OVERVIEW

Illuminate a world of possibilities with Simply Conserve®'s smart downlight retrofit. Change brightness and color based on your daily activity. Bring them to life by naming, grouping and sharing your smart downlights. With the touch of a finger or the ease of voice control, you can monitor and adjust your lights from anywhere.

CATALOG #		TYPE
PROJECT		
COMMENTS		DATE
PREPARED BY		

APP FEATURES

- Stay connected to your home or commercial building anywhere at any time using the Simply Conserve® app.
- Schedule automatic lighting to brighten and dim your home in sync with your schedule.
- Use Amazon Alexa or the Google Assistant for easy voice control.
- Control switch directly from your phone with no hub required.
- Adjust the downlight's color or tune the white light.
- Group several downlights under one control.
- Provide multiple users with full control capabilities.

DOWNLIGHT FEATURES

- Suitable for damp locations
- Matte white smooth-trim finish
- L70-rated lifetime of 50,000 hours
- Spring-loaded retention clips
- E26 adapter included

SYSTEM REQUIREMENTS

- Apples iOS 8 or higher
- Android 4.1x or higher
- 2.4GHz Wi-Fi Channel
- No hub required



No Hub
Required



Wi-Fi and
Bluetooth Low
Energy (BLE)-
Enabled



RGB-CCT
Adjustable

SOURCE	WATTAGE	FIXTURE TYPE	CCT	RGB	INC. OPTIONS
L = LED	12 = 12W	DL5/6 = Downlight 5" or 6" Nominal Size	CCT = 2200K - 6500K App Adjustable	RGB = Red, Green, Blue App Adjustable	WiFi = Wi-Fi Connectivity BLE = Bluetooth Low-Energy Connectivity



Get the Simply Conserve app



SPECIFICATIONS

CATALOG #	WATTS	CCT	LUMENS	EFFICACY	CRI	VOLTAGE	DIM
L12DL5/6-CCT-RGB-WiFi-BLE	12	2200-6500K	950	79 LPW	≥80	120V	Dimmable via app

DIMENSIONS

PRODUCT

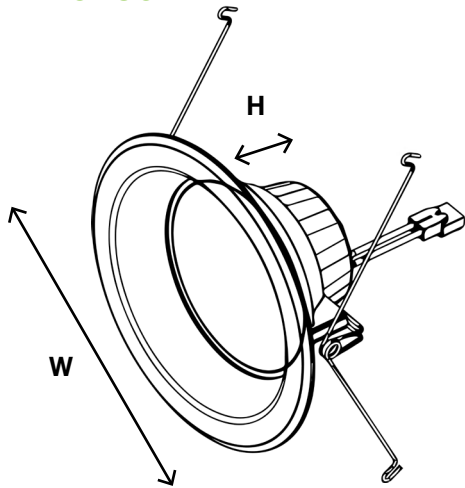

CASE

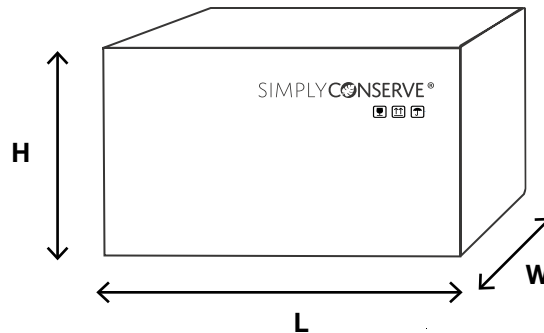

CATALOG #	W	H
L12DL5/6-CCT-RGB-WiFi-BLE	6.3"	2.8"

CATALOG #	L	W	H	CASE QTY.	GROSS WT.
L12DL5/6-CCT-RGB-WiFi-BLE	23.2"	17.7"	16"	30	16.55 lbs

5-Year Limited Warranty



AM Conservation warrants that this product is free from defects in material and workmanship for a period of 5 years from the date of the first purchase or the original distribution of the product under an energy conservation program, subject to the proper installation and/or use of the product. For full standard limited product warranty, please visit amconservation.com/warranties.

For warranty claims, please contact:

customer@amconservation.com

To learn more, please visit:

www.amconservation.com